



## SRLF系列双筒回油管路过滤器 SRLF DUPLEX RETURN LINE FILTER SERIES

### (一) 简介

SRLF双筒回油管路过滤器是由两只单筒过滤器及二位六通换向阀组成，结构简单，使用方便，并带有旁通阀及滤芯污染堵塞发讯器，以达到保证系统安全的目的。

在工作过程中，单筒过滤器滤芯堵塞到一定程度需清洗或更换滤芯时，要停止主机工作来更换滤芯，这样不仅浪费时间更不能满足主机连续工作需要，双筒过滤器有效地解决了单筒过滤器这方面的缺陷，在不停机的情况下可清洗或更换滤芯来保证主机连续工作。

它的工作特点是当一只过滤器滤芯堵塞而需更换时，不必停止主机工作，只要打开压力平衡阀并转动换向阀，另一只过滤器即可参加工作，然后更换已堵塞的滤芯，需更换滤芯侧过滤筒，允许

少量内泄漏。

本过滤器广泛应用于重型机械、矿山机械、冶金机械等液压系统。

### INTRODUCTION

The SRLF series filter is composed of two single bowl filters and a 2-position 6-way directional valve. It is simple in structure and easy to use. There is by-pass valve and a contamination indicator in it for protecting the hydraulic system safety.

The feature of this filter allows continues operation even during replacing element clogged by contaminants. Turning the directional valve, another filter will be working in the hydraulic system, the clogged element should be changed in time.

This series filter is widely used in the hydraulic systems of heavy duty,

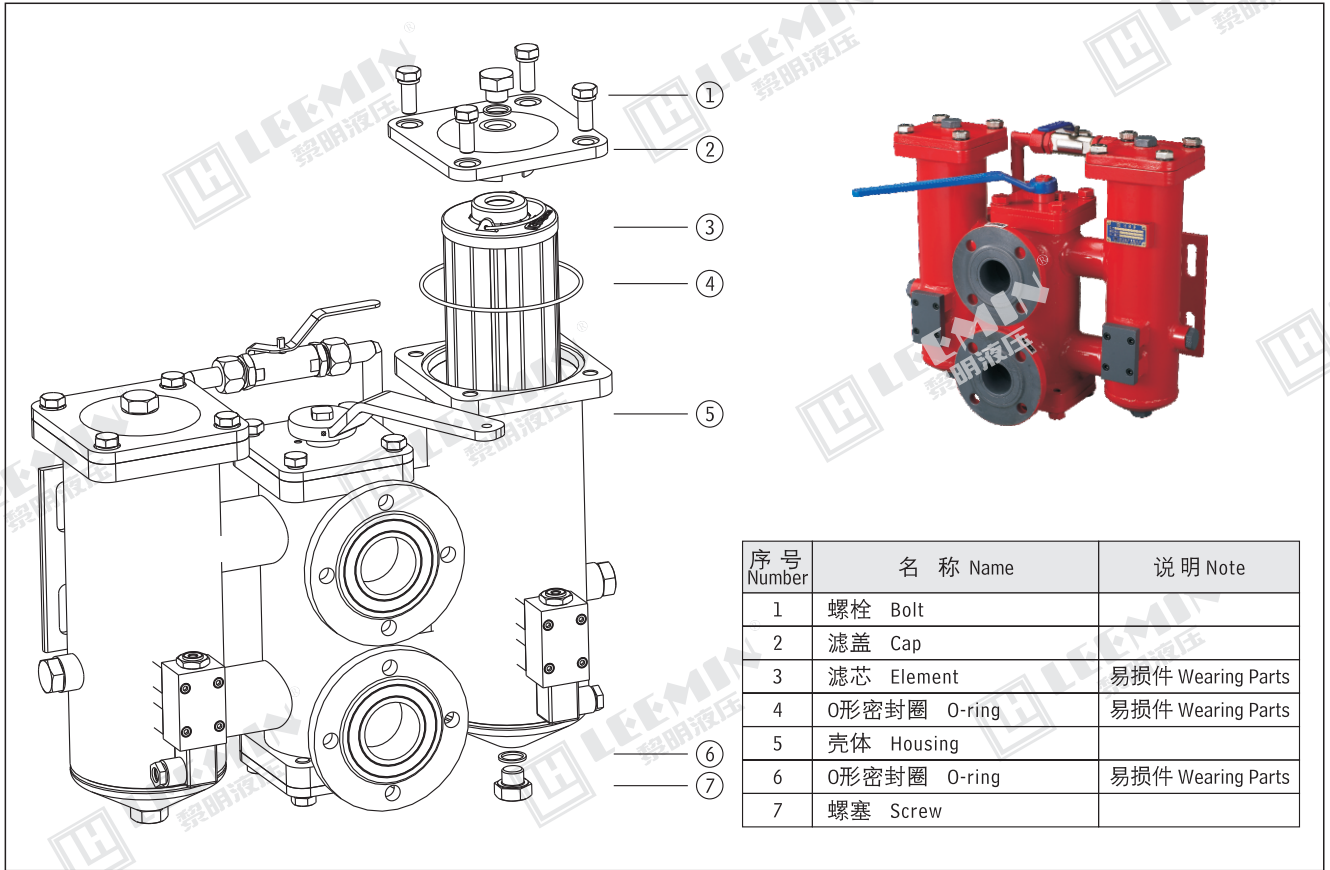

### (二) 型号说明 MODEL CODE

SRLF · □ - □ × □ P

双筒回油管路过滤器  
Duplex return line filter

P:带CMS型发讯器 With CMS indicator  
省略: 不带发讯器 Omit if without indicator

过滤精度: Filtration accuracy(μm)

公称流量: Flow rate:(L/min)

BH:介质为水-乙二醇 Water-glycol

省略: 介质为一般液压油 Omit if use hydraulic oil

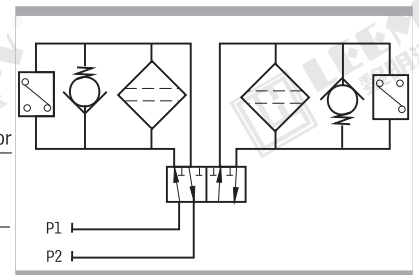



### (三) 技术参数 TECHNICAL DATA

型号 Model	公称流量 Flow rate (L/min)	过滤精度 Filtr. ( $\mu$ m)	通径 Dia. (mm)	公称压力 Press. (MPa)	压力损失 Pressure loss(MPa)		发讯装置功率 Indicator power	重量 Weight (kg)	滤芯型号 Model of element
					Initial	Max.			
SRLF-60 × * P	60	1	25	1.6	$\leq 0.08$	0.35	24V/48W	13.2	SFX-60 × *
SRLF-110 × * P	110		25					13.7	SFX-110 × *
SRLF-160 × * P	160	3	40					29.5	SFX-160 × *
SRLF-240 × * P	240	40	32.0					SFX-240 × *	
SRLF-330 × * P	330	5	50				52.5	SFX-330 × *	
SRLF-500 × * P	500	10	50				58.5	SFX-500 × *	
SRLF-660 × * P	660	20	80				77.0	SFX-660 × *	
SRLF-850 × * P	850	80	81.0				SFX-850 × *		
SRLF-950 × * P	950	30	100				112	SFX-950 × *	
SRLF-1300 × * P	1300	100	100				121	SFX-1300 × *	

注: \*为过滤精度。若使用介质为水—乙二醇, 使用压力1.6MPa, 公称流量110L/min, 过滤精度10 $\mu$ m, 带发讯器。则过滤器型号为SRLF·BH-110×10P, 滤芯型号为SFX·BH-110×10

Note: \*is represents filtration. If the filter fluid is water-glycol, usage pressure 1.6MPa, flow rate 110L/min, filtration accuracy 10 $\mu$ m and the filter equipped with indicator. The model of the filter is SRLF·BH-110×10P, the model of element is SFX·BH-110×10

### (四) 安装外形尺寸 MOUNTING SIZE

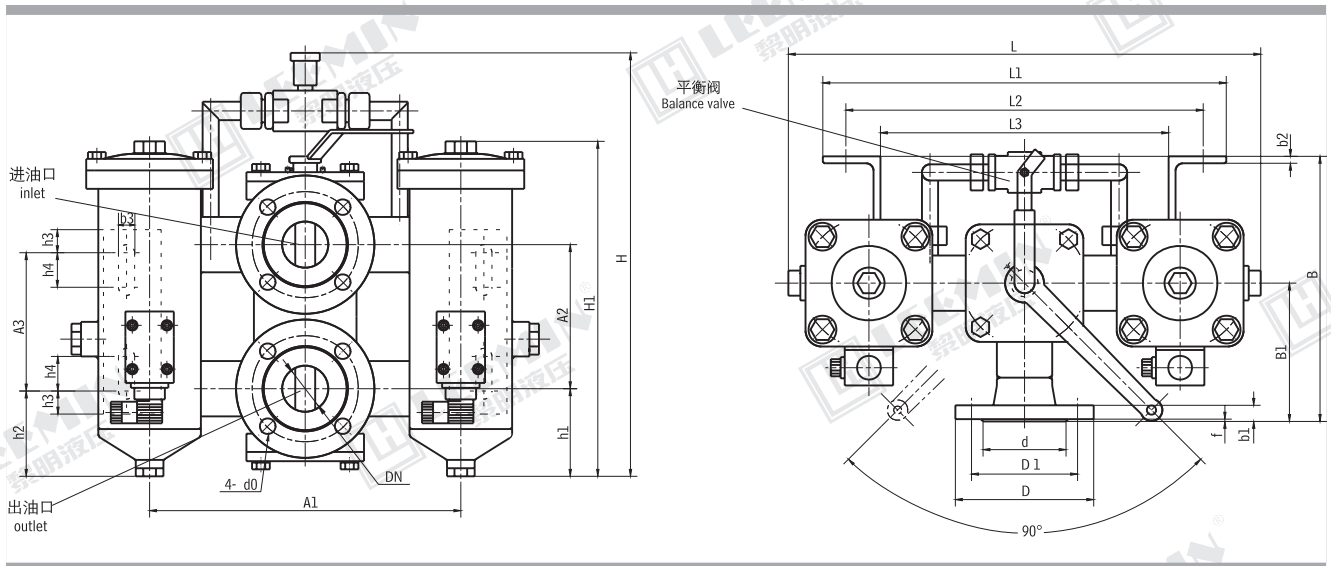

型号 Model	尺寸 Size (mm)																							
	DN	D	D1	d	d0	f	b1	A2	h1	B1	B	L1	L2	L3	b2	h2	h3	h4	A3	b3	L	A1	H*	H1
SRLF-60 × * P	25	92	68	50	11	2	14	98	60	100	168	232	204	160	4	65	16	20	90	11	316	200	258	222
SRLF-110 × * P								125	76	120	230	310	250	75										
SRLF-160 × * P	40	120	92	72	13.5		14	125	76	120	230	350	310	250	6	75	20	30	120	14	405	270	361	293
SRLF-240 × * P								145	90	130	254	380	340	280										90
SRLF-330 × * P	50	140	110	90	13.5		14	145	90	130	254	380	340	280	6	90	20	30	120	14	486	310	395	368
SRLF-500 × * P								145	90	130	254	380	340	280										90

\*注: SRLF-60 × \*P及SRLF-110\*P无平衡阀, H为扳手到底部高度。

Note: SRLF-60 × \*P and SRLF-110 × \*P have not balance valve, H is the height between the spanner and the base.



**LEEMIN**  
黎明液压

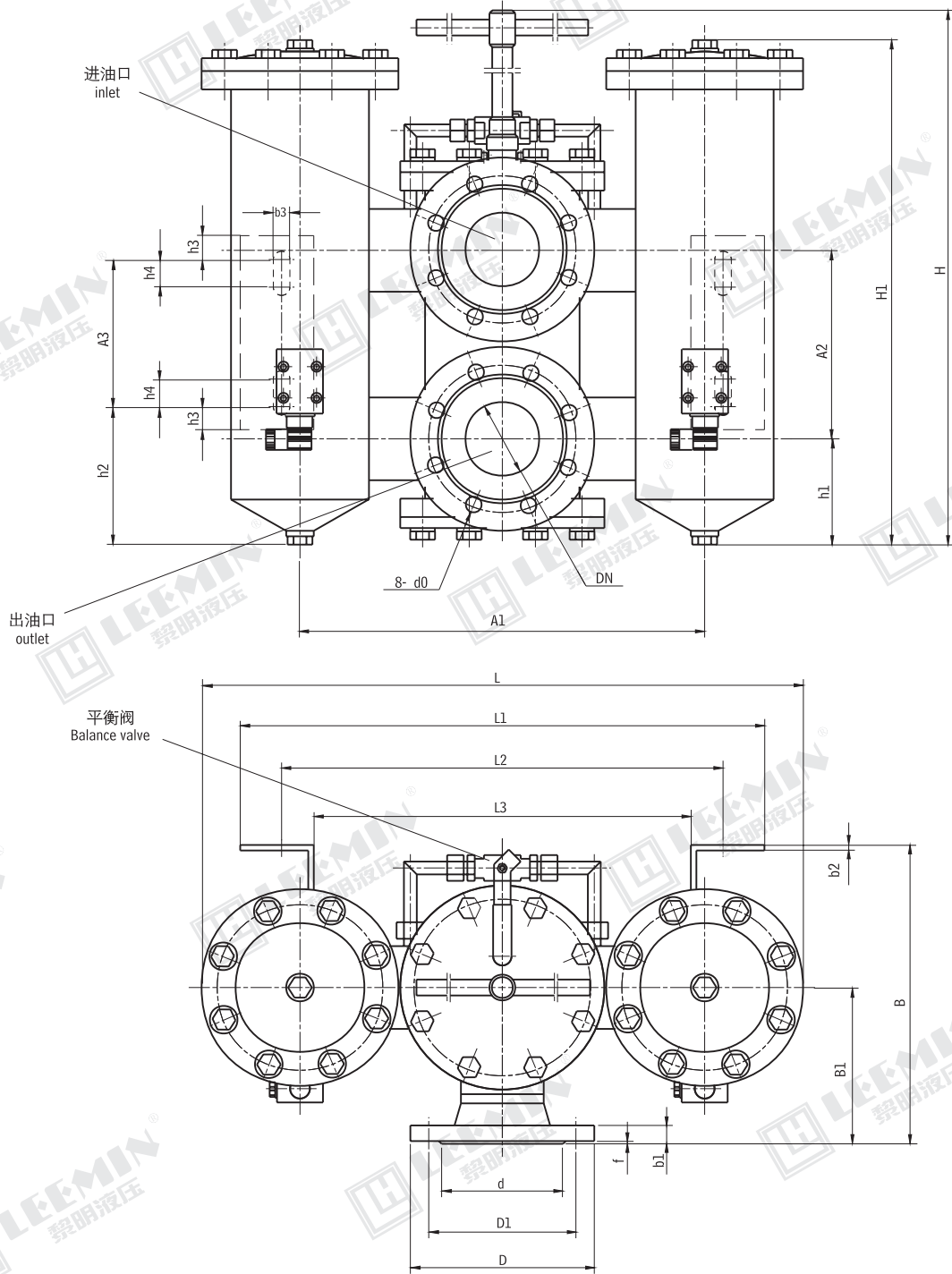

型号 Model	尺寸 Size (mm)																							
	DN	D	D1	d	d0	f	b1	A2	h1	B1	B	L1	L2	L3	b2	h2	h3	h4	A3	b3	L	A1	H	H1
SRLF-660 × P	80	200	160	133	17.5	3	20	205	115	170	325	520	480	410	6	150	25	30	160	18	654	440	790	548
SRLF-850 × P								225	132	190	360	630	560	470		130	30	40	300	22	774	520	840	728
SRLF-950 × P	100	220	180	158	17.5	3	20	225	132	190	360	630	560	470	6	130	30	40	300	22	774	520	840	609
SRLF-1300 × P								225	132	190	360	630	560	470		130	30	40	300	22	774	520	840	728